



The B0034 Marine Loading Arm is designed to serve big tanker ships up to 250.000 DWT and to meet the most stringent specifications and requirements of the petrochemical industry. Its capability has been proven within many years of trouble free operation worldwide.

The B0034 design includes a special support frame for the inboard arm and a rigid link pantograph balancing system with independent counterweights directly linked to the inboard- and outboard arm.

Thus providing that accurate balance is definitely ensured throughout all manoeuvring and connecting positions.

The special design of the inboard arm support structure additionally provides the optimum in regards to operational safety aspects, low weight of the arm and lowest wind loads imposed to the jetty structure.

The B0034 is available:

- ◆ in sizes from 8" up to 16"
- ◆ for pressure rates from PN 10 up to PN 40
- ◆ materials: carbon steel, low temperature steel, stainless steel
- ◆ for all mineral oil products (incl. LPG)
- ◆ for temperature range of -50 °C up to +200 °C

For any deviations we shall be glad to offer you individual solutions.

The advantages in comparison with hose loading facilities are ease of handling, higher availability/flexibility, less man power and minimum maintenance required by maximal operational safety and minimised operational cost (cost of ownership).

The B0034 is designed for hydraulically operation and can be fitted with the most sophisticated ancillary equipment.

Additional equipment is available.

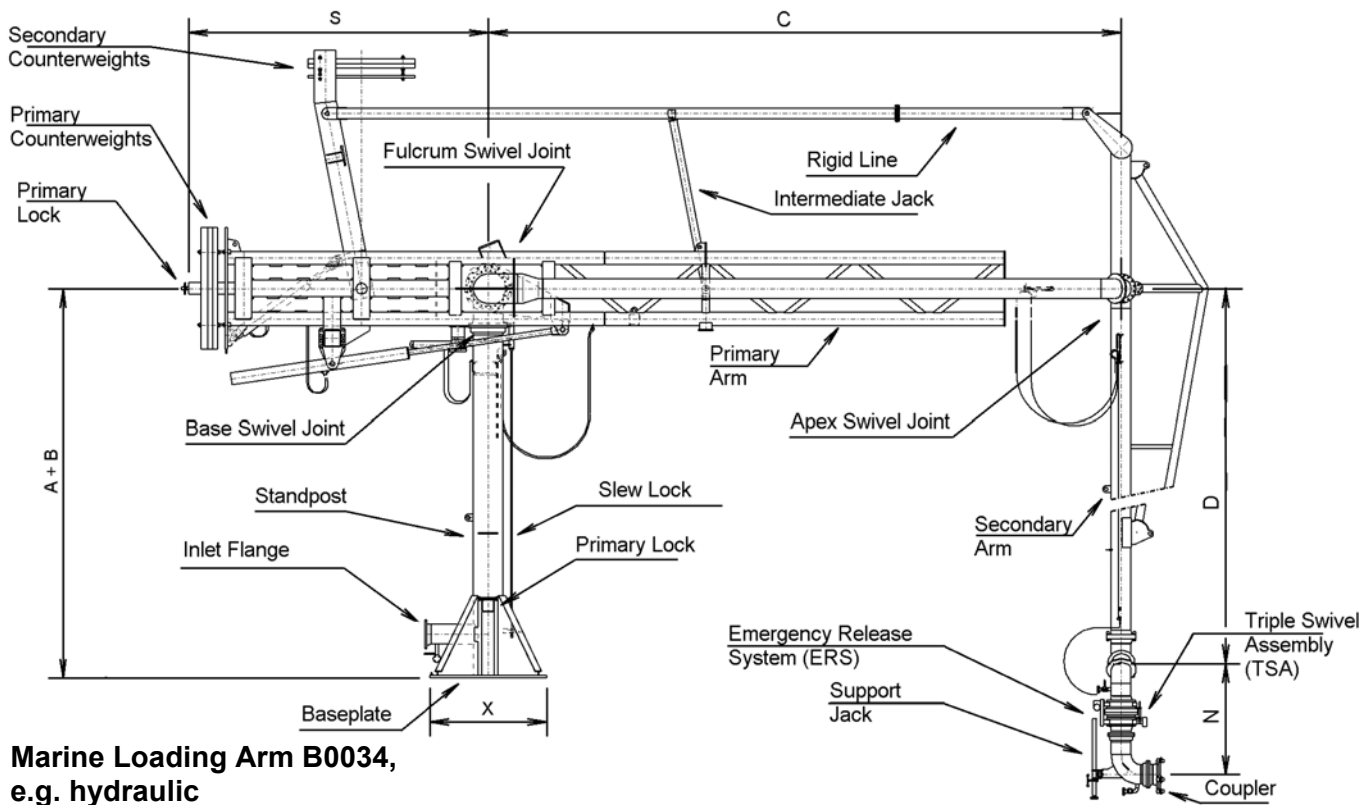

**Marine Loading Arm B0034, e.g. hydraulic**

TYPICAL DIMENSIONS, WEIGHTS AND BENDING MOMENTS (incl. emergency release system)									
Size	Stand Pos Height	X	C	D	N	S	flow rate	weight	bending moment
inch	mm	mm	mm	mm	mm	mm	m <sup>3</sup> /h	KN	KNm
8"	7 000	1 500	10 000	10 000	1 350	6 000	1 100	190	490
10"	8 000	1 500	10 000	10 000	1 750	7 000	1 700	240	760
12"	8 000	1 500	12 000	12 000	2 100	7 000	2 500	320	850
16"	8 000	1 500	13 000	13 000	2 400	7 000	4 000	380	970

**Design:**

- ◆ Fully balanced via rigid link pantograph system incl. separated counterweights for inboard- and outboard arm
- ◆ special support frame to reduce mechanical loads imposed to the inboard arm
- ◆ most convenient light weight design available world-wide
- ◆ for transfer of all products, e.g. mineral oil, chemicals, liquefied gases
- ◆ available in carbon steel, low temperature steel and stainless steel
- ◆ swivel joints either as welded-in or flanged version
- ◆ seals available in Buna-N, Viton, PTFE or any other specific material depending on application
- ◆ pressure rates of PN 10 to PN 40 or any other international standards. Higher pressure rates are possible
- ◆ temperature range from -50 °C (e.g. LPG) to +200 °C (e.g. Bitumen). Other temperature criteria are possible.

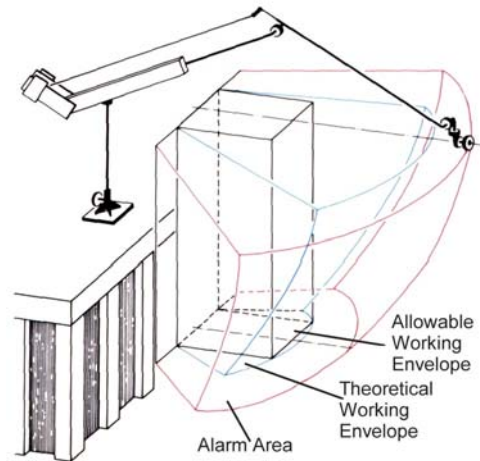

**Typical Accessories:**

Vacuum Breaker	Working Envelope Warning System	Insulating Flange
Nitrogen Purge Line	Purge Line	Hydr. Operation
Drainage Connections	Manual Quick Coupler	Vapour Return Line
Emergency Release System (ERS)	Hydr. Quick Coupler	